

OWNER'S MANUAL

Model: AG55-HSSTH

Black (5302115-BLK)

Blue (5302115-BLU)

(55 Gallon 'Standard' Hay Sprayer)

- 55 Gal. Corrosion-Resistant Polyethylene Tank
- 12 Volt Diaphragm Pump, 2.2 GPM, 100 PSI
- 3-Nozzle Boom Assembly

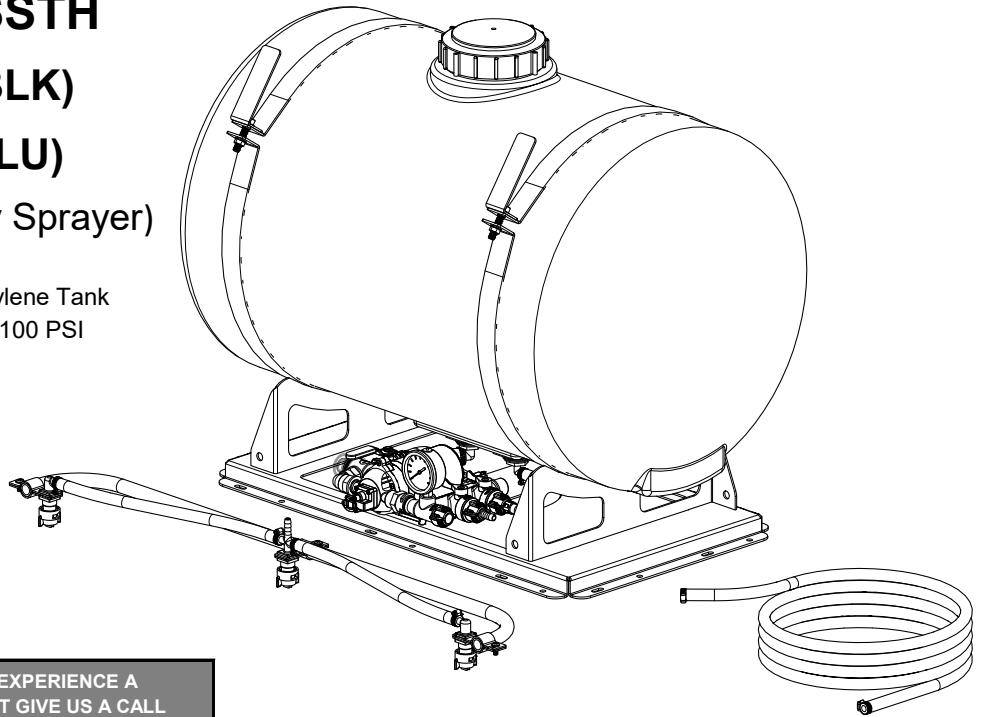

IF YOU SHOULD HAVE A QUESTION OR EXPERIENCE A PROBLEM WITH YOUR AG SPRAY PRODUCT GIVE US A CALL

BAKERSFIELD, CA 877-724-2236	COLUMBUS, NE 800-274-1025	DOTHAN, AL 800-227-4098
FARGO, ND 701-280-2862	HOPKINSVILLE, KY 800-637-7172	MANKATO, MN 507-388-6295
NEWTON, KS 800-394-7662	PASCO, WA 800-634-2026	TEMPE, AZ 877-974-7166

BEFORE YOU CALL, PLEASE HAVE THE FOLLOWING INFORMATION AVAILABLE: SALES RECEIPT & MODEL NUMBER. IN MOST CASES, AN AG SPRAY EMPLOYEE CAN RESOLVE THE PROBLEM OVER THE PHONE



WARNING: To reduce the risk of injury, the user must read and understand the operator's manual before using this product.



WARNING: Cancer and Reproductive Harm
www.P65Warnings.ca.gov

Retain a copy of your receipt for your unit, as it will be required to validate any warranty service
Products are warranted against manufacturer or workmanship defects for one year from date of purchase for home owner usage and 90 days for commercial usage.

For technical assistance, visit our website @ www.agspray.com or call: Toll Free to one of the above phone numbers
Our Technical Support Representatives will be happy to help you.
To obtain prompt, efficient service, always remember to give the following information...

- Correct Part Description and/or part number
 - Model #/Serial # of your sprayer

Part descriptions and numbers can be obtained from the illustrated parts list section(s) of this manual.

General Information

Thank you for purchasing this product. The purpose of this manual is to assist you in operating and maintaining your sprayer.

Assembly Instructions

Your sprayer has been mostly assembled at the factory.

One requirement will be for you to hook up your battery leads to a fully charged 12 Volt battery. The red wire must be connected to the "hot" lead and the black wire should be connected to the ground.

CAUTION: Always check the vehicle load rating before using this sprayer. Do not exceed the recommended rating.



www.agspray.com

[5194621

(01/19)]

IMPORTANT: Remove tank lid and be sure the tank is clean and free of any foreign material. Rinse tank out of any tank residue before filling with water to test.

Testing the Sprayer

NOTE:

It is **VERY** important for you to test your sprayer with plain water before actual spraying is attempted. This will enable you to check the sprayer for leaks without the possibility of losing any expensive chemicals.

Fill the tank about 1/2 full with plain water and drive to the starting place for spraying.

When you are ready to spray, turn the boom valve to the "on" position (Detail A). This will start solution spraying from the tips of the boom. The pressure will decrease slightly when the boom is spraying.

Adjust the pressure by turning the "ON/OFF" valve lever on the pressure adjust valve (Detail B). Make sure your pattern is sufficient. You may down-pressure the system by 'bypassing' solution back into the tank. This is achieved by opening the pressure adjust valve. Regulating pressure is done in this manner.

Read the operating instructions and initially begin spraying by closing the 'Pressure Adjust' valve and opening the boom line valve (Detail A). This will enable the air in the line to be eliminated (purged) through all the tips, while building pressure. When everything tests all right (no leaks and good pressure), add the desired chemicals to the mixture and water combination and start your spraying operation. Adjust the pressure and spray as you did in the testing procedure.

Conditions of weather and terrain must be considered when setting the sprayer. Do not spray on windy days. Protective clothing must be worn in some cases.

Be sure to read the chemical label(s) before application!

Operation

The pumping system draws solution from the tank, through the strainer and to the pump. The pump forces the solution under pressure to the handgun or boom nozzles.

Connect the lead wire to a fully charged 12 volt battery. You may use either a stand-alone battery or the battery on your towing vehicle. Connect to the positive (red) terminal first, then connect to the negative (black) terminal. Then connect the end of the lead wire to the end of the pump. When disconnecting, disconnect the end of the pump wire from the lead wire, then disconnect the negative (black) connection and finally the positive (red) connection. The lead wire has an On/Off switch to activate the pump. "-" is on and "O" is off.

Fill the tank part way with water and then add the desired amount of chemical to be sprayed. Finish filling tank to proper level. Turn the pump on and by depressing the "-" side of the rocker switch. The pump is equipped with a pressure switch that is pre-set at the factory to shut the pump off when all discharges are closed.

The pump will turn back on when one of the following actions occurs:

- ◆ Boom valve is opened to broadcast spray with the boom.
- ◆ Pressure adjust valve is opened to re-circulate solution back into the tank.

When spraying with either the boom or the handgun, pressure may be reduced by slowly opening the pressure adjust valve until desired pressure is achieved. Opening the valve decreases pressure, closing the valve increases pressure. When spraying with the boom, the proper method to set the pressure is to open the boom valve completely and if a lower pressure is desired, then slowly open the pressure adjust valve until that pressure is obtained.

For the safest and most efficient chemical application, you will need to calibrate your sprayer using the tip and speed charts. Once you have determined the proper speed and pressure settings, you will need to consult your chemical label for the amount of chemical to be added to the tank. Read the entire label. Use only according to label directions.

Manifold Valves CLOSED

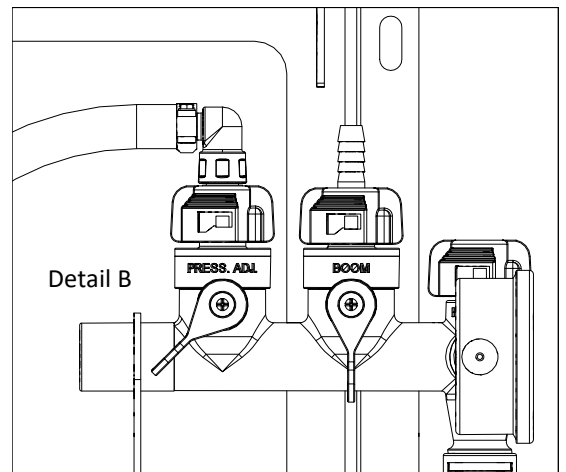
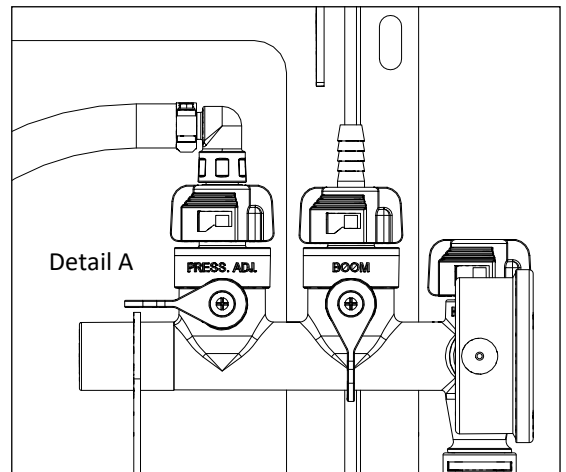
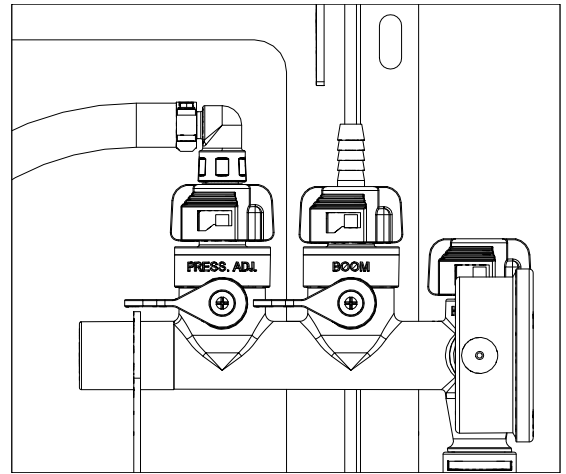

Speed Chart			
Speed in M.P.H. (Miles Per Hour)	Time Required in seconds to travel a distance of		
	100 Ft.	200 Ft.	300 Ft.
1.0	68 sec.	136	205
2.0	34	68	102
3.0	23	45	68
4.0	17	34	51
5.0	14	27	41
6.0	11	23	34
7.0	9.7	19	29
8.0	8.5	17	26

Spray Tip Rate Chart (20" Spacing)							
Tip No.	Pressure (psi)	Capacity (GPM)	Gallons Per Acre - Based on Water				
			4 MPH	5 MPH	6 MPH	8 MPH	10 MPH
XR11001VS	15	.061	4.5	3.6	3.0	2.3	1.8
	20	.071	5.3	4.2	3.5	2.6	2.1
	30	.087	6.5	5.2	4.3	3.2	2.6
	40	.10	7.4	5.9	5.0	3.7	3.0
Tip No.	Pressure (psi)	Capacity (GPM)	Gallons Per 1000 Sq. Ft. - Based on Water				
			1 MPH	2 MPH	3 MPH	4 MPH	5 MPH
XR11001VS	15	.12		.21	.14	.10	.08
	20	.14		.24	.16	.12	.10
	30	.17		.30	.20	.15	.12
	40	.20		.34	.23	.17	

Calibration

Chemical labels may show application rates in gallons per acre, gallons per 1000 square feet or gallons per 100 square feet. You will note that the tip chart shows 2 of these rating systems. Once you know how much you are going to spray, then determine (from the tip chart) the spraying pressure (PSI), and the spraying speed (MPH).

Determining the proper speed of the pulling vehicle can be done by marking off 100, 200 & 300 feet. The speed chart indicates the number of seconds it takes to travel the distances. Set the throttle and with a running start, travel the distances. Adjust the throttle until you travel the distances in the number of seconds indicated by the speed chart. Once you have reached the throttle setting needed, mark the throttle location so you can stop and go again, returning to the same speed.

Add water and proper amount of chemical to the tank and drive to the starting place for spraying.

Using the Boom Nozzles

Four things must be considered before spraying with the boom.

1. How much chemical must be mixed in the tank.
 2. Rate of spray (gallons per acre to be sprayed).
 3. What pressure (p.s.i.) will be used.
 4. Speed traveled (mph) while spraying.
- * Refer to the chemical label to determine your chemical mixture
 - * See the tip chart to determine the pressure to be used. The chart will also show the speed used when spraying.
 - * Start the pump and open the valve to the boom nozzles.
 - * Check the spray pattern. Usually you can see the coverage better on a solid concrete surface, such as a driveway.

Maintenance During/After Spraying

Periodically check the strainer and clean the screen on your intake line.

Proper care and maintenance will prolong the life of your sprayer.

After use, drain the tank and store or dispose of chemical properly. Fill the sprayer half way with clean water. Start the pump and allow the water to pump through the entire plumbing system and nozzles. Drain and then refill half full, add the recommended amount of a good quality tank cleaner, such as FIMCO Tank Neutralizer and Cleaner. (If no tank cleaner is available, you may substitute dish soap for this step, about 1-2 oz. per gallon). Turn pump on and circulate through system for 15 minutes and then spray out through boom and handgun nozzles. Refill sprayer half way with clean water and repeat. Follow the chemical manufacturer's disposal instructions of all wash or rinsing water.

If boom or handgun nozzles need cleaning, remove them from the sprayer and soak in warm soapy water. Clean with a soft bristled brush or toothpick if necessary. Never use a metal object. Even the slightest damage can change the flow rate and spray distribution. Water rinse and dry the tips before storing.

WARNING: Some chemicals will damage the pump valves if allowed to soak untreated for a length of time! ALWAYS flush the pump as instructed after each use. DO NOT allow chemicals to sit in the pump for extended times of idleness. Follow the chemical manufacturer's instructions on disposal of all waste water from the sprayer.

Winter Storage

Prepare the sprayer for end-of-season storage by running RV antifreeze through the system. This will keep internal parts lubricated, protect against corrosion and keep the unit from freezing. *Note: RV antifreeze is non-toxic and biodegradable and generally safer for the environment than automotive antifreeze.*

Before storing your sprayer for winter or long term storage, thoroughly clean and drain it as much as possible. Then pour enough pink RV antifreeze into the tank so that when the pump is turned on you can pump the antifreeze throughout the entire plumbing system, including the pressure adjust (bypass) line. Make sure to operate the boom and handgun until you see pink fluid spraying from the nozzles. Leave any remaining antifreeze in the tank. Before your next usage, rinse the antifreeze from the sprayer with clean water.

It is nearly impossible to drain all of the water from the sprayer and any trapped water can freeze in cold weather and damage parts of the sprayer. Pumping the antifreeze through the system will displace the water and help prevent this damage.

Removing from storage: drain the antifreeze. Fill the tank with fresh water and run through the system. Dispose of antifreeze and flush water properly.

DO

- Clean and rinse your pump after each use with Fimco Tank Neutralizer
- Winterize your pump or sprayer by rinsing, draining and running RV Antifreeze through it before storing for the winter.
- Use clean water for your spray mixture
- Store inside a building when not in use.

DON'T

- Use to pump bleach.
- Use to pump petroleum products, such as diesel fuel, gasoline or kerosene
- Leave your pump sit with spray mixture in it for extended periods
- Use dirty or unfiltered water for spraying

Ref. #	Mfg. Part #	Description	Qty.
1	94-375-18	Switch Assembly	1
2	94-374-08	Check Valve Assembly	1
3	94-378-00	Upper Housing	1
4	94-390-05	Valve Assembly	1
5	94-385-35	Drive Assembly	1

Base Plate Grommets (Pkg/4): #5075019

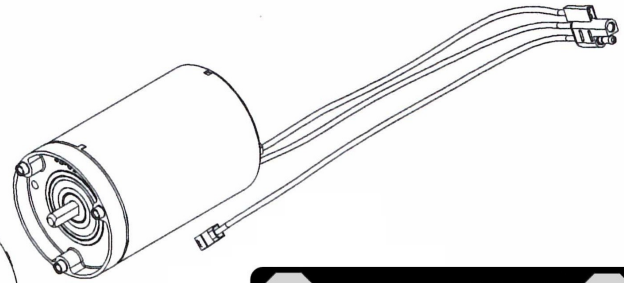
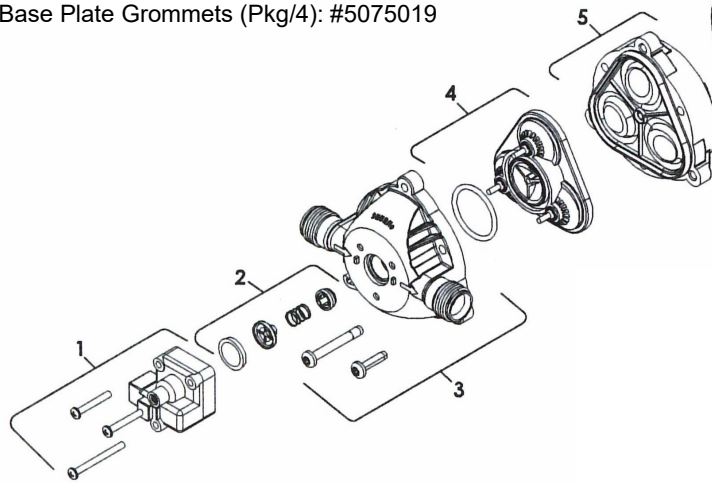

STOP WARNING STOP
 DO NOT USE PUMP IN AN EXPLOSIVE ENVIRONMENT. DO NOT USE TO PUMP FLAMMABLE/COMBUSTIBLE FLUIDS, GASOLINE, KEROSENE, FUEL, OIL, ETC.

Exploded View/Parts List:
SHURflo Pump
 2.2 GPM, 100 PSI
 (Model: 5151074)

Troubleshooting the Pump:

Motor does not run:

- Check for loose wiring connection(s).
- Make sure the 'ON/OFF' switch in the lead wire assembly is in the 'ON' position. "I" is the 'ON' position and 'O' is the 'OFF' position.
- Check for defective switch assembly. Make sure you are connected to a good 12 volt power source. Make sure any on/off switches are in the 'on' position. Disconnect the wires off of switch assembly and short them out. If your pump runs when you do this, your switch assembly will need to be replaced.
- Check the fuse, if applicable.
- Check for low voltage at the power supply.

Pump does not prime:

- Check for air leaks in supply line.
- Check for debris in the valve assembly.
- Check for defective valve assembly.
- Check for clogged strainer/filter.
- Check for cracks in the pump housing.
- Check for empty product supply.

Pulsating flow (surging):

CAUTION
PRESSURE SWITCH OPERATION
 Pressure switch is pre-set at the factory. Improper adjustment of the pressure switch, may cause severe overload or premature failure. If the pump is subjected to rapid cycling during normal operation, or infrequent periods, damage may occur.

- Check for defective switch assembly.
- Check for leaks in the discharge line.
- Check for restriction in the discharge line.
- Check for debris in nozzle orifice.
- Discharge hose may be too long.
- Check for clogged strainer.

Motor continues to run after discharge is shut off:

- Check for empty product supply.
- Check for open bypass valve. (if equipped)
- Check for low voltage.
- Check for leak in discharge line.
- Check for defective or dirty valve assembly.
- Check for defective switch assembly.

Exploded View/Parts List: AG55-HSSTH (5302115-BLK) (5302115-BLU)

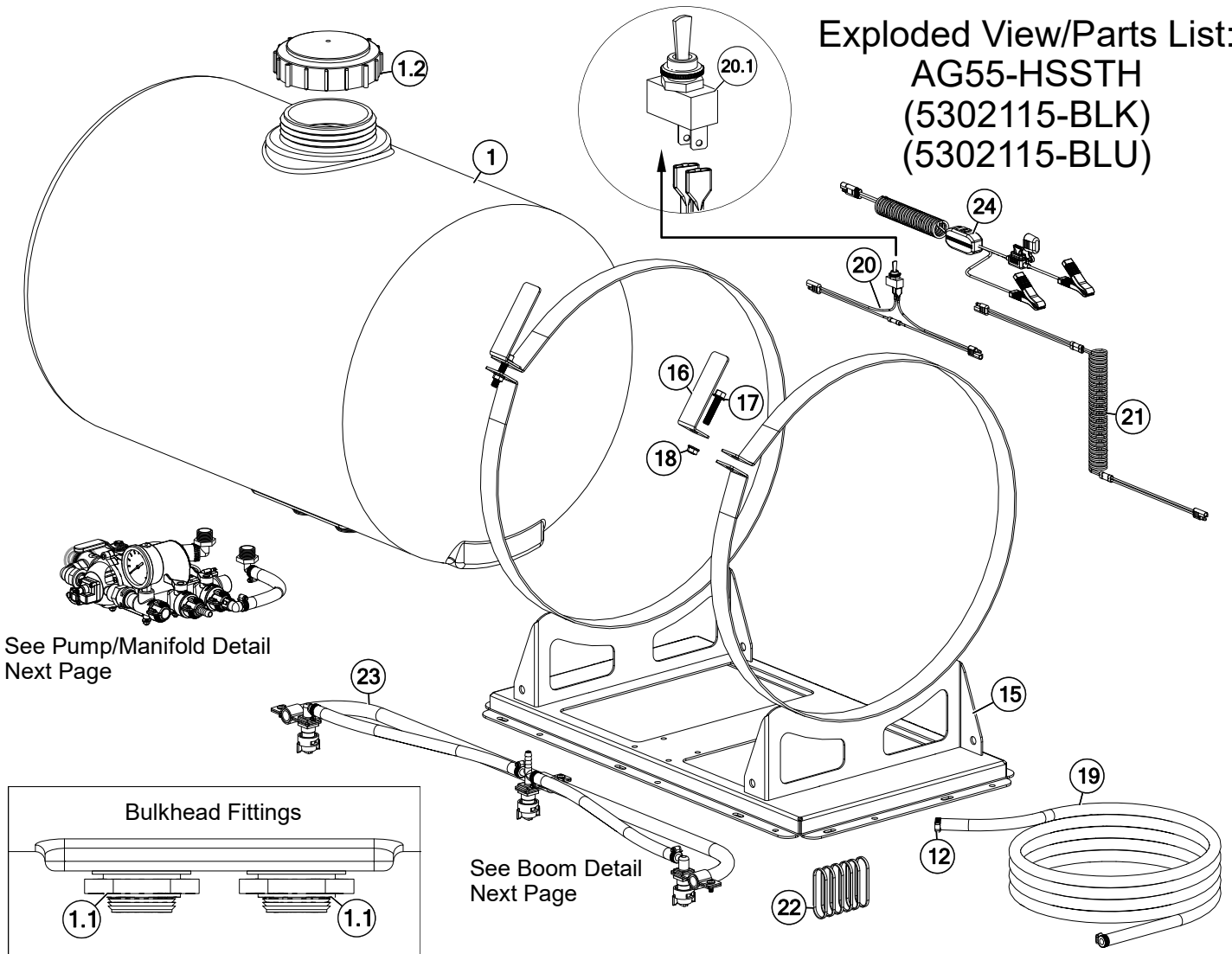

See Pump/Manifold Detail
Next Page

See Boom Detail
Next Page

Ref. #	Part #	Description	Qty
1	5169148	55 Gallon Horizontal Tank (Yellow)	1
1.1	5273736	3/4" Double-Threaded Poly Tank Bulkhead Fitting	2
1.2	5058189	5" Threaded Tank Lid Only	1
2	5010207	Poly Elbow, 3/4" MNPT x 1/2" HB	1
3	5020593	Hose, 1/2"-1 Brd. x 5"	1
4	5051114	Hose Clamp (1/2")	2
5	5281398	SHURflo 2.2 Pump Assembly	1
5.1	5281397	Intake Sub-Assembly (Brass Shut-Off)	1
5.1.1	5067131	Poly Fitting, 1/2" MNPT x 1/2" HB	1
5.1.2	5143197	1/2" T-800 Brass Ball Valve	1
5.1.3	5116417	Poly Inline Strainer 1/2 MNPT	1
5.1.3.1	5046451	Poly Strainer Cap	1
5.1.3.2	5072533	Strainer O-Ring	1
5.1.3.3	5116452	Strainer Screen	1
5.1.3.4	5058205	Clear Strainer Bowl	1
5.1.4	5010236	Poly Elbow, 1/2" FNPT x 1/2" FNPT	1
5.2	5151074	SHURflo Pump: 12V, 2.2 GPM, 100 PSI, 1/2" MSPT	1
5.3	5117166	#10-24 x 1 1/4" Phillips Truss Head Mach. Screw	3
5.4	5005456	3/4" Port to 1/2" Female NPT Adapter	1
6	5005457	Port Adapter Clip	1
7	5281391	Quick Connect Manifold Assembly	1
7.1	5302347	Quick Connect Manifold (Body ONLY)	1
7.1.1	5072514	O-Ring - Pump Port Connection	1
7.2	5143430	Flat Washer - Hose Barb Seal	2
7.3	5143435	Quarter Turn Cap Plug	1
7.4	5143431	QC Manifold - 3/8" Hose Straight Barb	1
7.5	5143429	Quick Connect Quarter Turn Cap	2
7.6	5302802	QC Manifold 3/8 Swivel 90° Elbow Assembly	1
8	5037945	Manifold Support Brace	1
9	5117166	#10-24 x 1 1/4" Phillips Truss Head Mach. Screw	1

Ref. #	Part #	Description	Qty
10	5167080	Gauge, Liquid-Filled, 0-200 PSI	1
11	5020594	Hose, 3/8"-1 Brd. x 9"	1
12	5051144	Hose Clamp (3/8")	4
13	5010206	Poly Elbow, 3/4" MNPT x 3/8" HB	1
14	5006186	#10-24 Hex Flange Whiz Nut, ZP	4
15	5277269	55 Gallon Rack Weldment (Specify Black or Blue)	1
16	5038783	Hose Bracket	2
17	5034675	H.H.C.S. Flanged 3/8"-16nc x 4-1/2"	2
18	5006259	3/8-16nc Hex Flanged Whiz Nut Gr. 5	2
19	5020158	Hose, 3/8"-1 Brd. x 30 Ft.	1
20	5157222	Switch & Wire Assembly	1
20.1	5157016	Mini Toggle Switch, Model 1700 Series	1
21	5157221	Wiring Harness (21 Ft)	1
22	5133094	Nylon Cable Tie	6
23	5277901	Hay Sprayer Boom	1
23.1	5100623	Spray Boom	1
23.2	5272861	Vari-Quick Clamp	3
23.3	5277887	Nozzle Harness/Hay Sprayer	1
23.3.1	5056113	Nozzle Body - QJ - Elbow - 3/8"	2
23.3.2	5056115	Nozzle Body - QJ - Cross - 3/8"	1
23.3.3	5116041	Check Valve Strainer (Brass)	3
23.3.4	5018207	TeeJet Spray Tip (XR11001VS)	3
23.3.5	5046295	Quick TeeJet Cap (Black) & Washer	3
23.3.5.1	5016157	Seat Washer - EPDM - QJ Caps	1
23.3.5.2	5046214	Quick TeeJet Cap ONLY (Black)	1
23.3.6	5020511	Hose, 3/8"-1 Brd. x 23"	2
23.3.7	5051144	Hose Clamp (3/8")	4
24	5278114	96" Lead Wire Assembly w/15A Fuse & 30A Clips	1
24.1	5157238	15 Amp Regular Blade Fuse	1

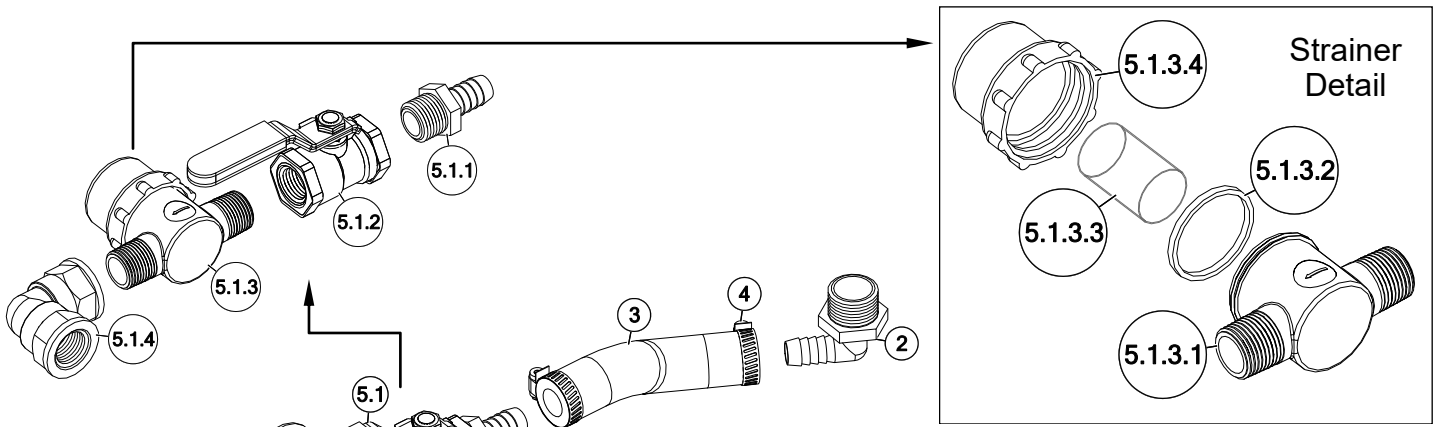

Pump/Manifold Detail

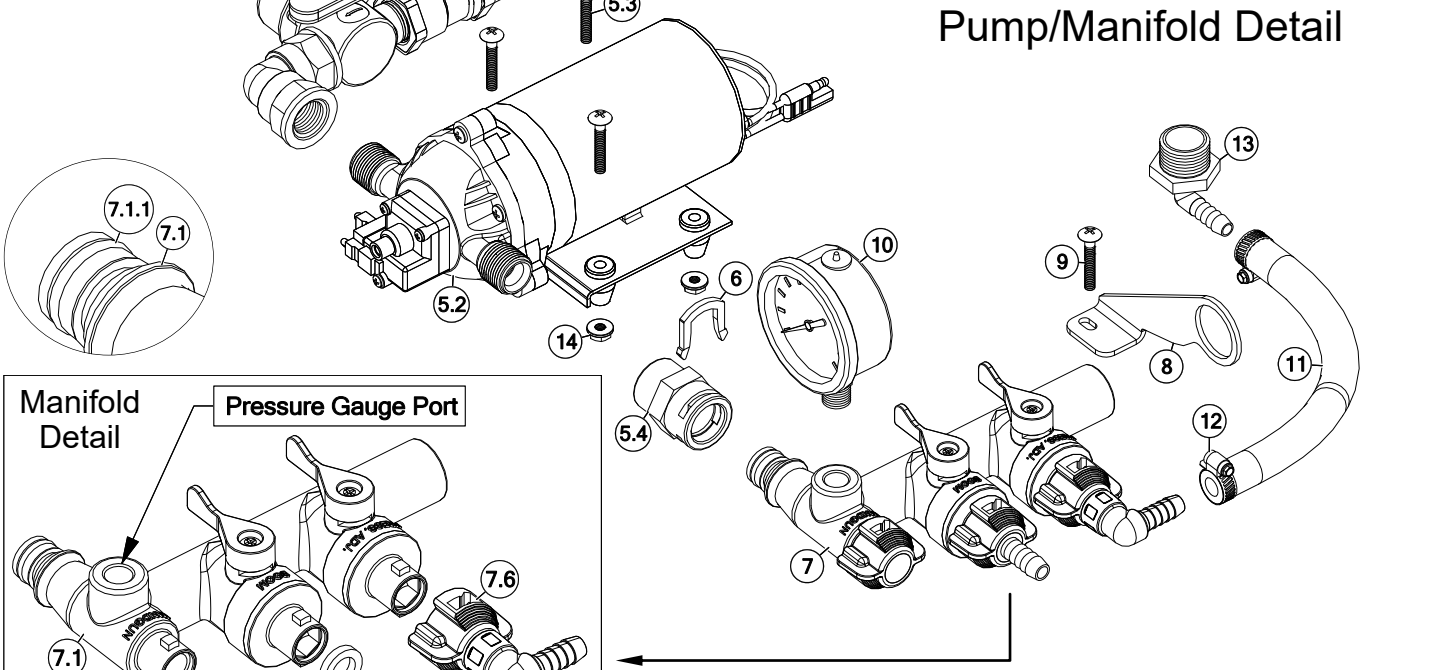

Refer to the Parts List
Previous Page
for Part Numbers.

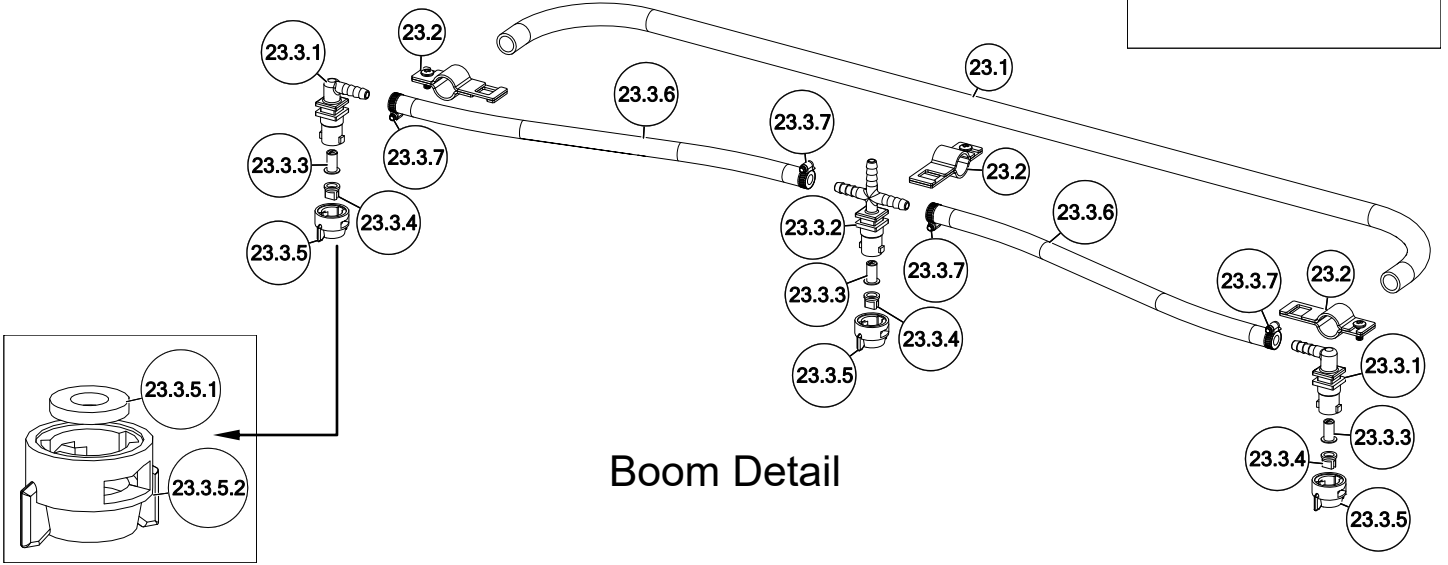

Based on the minimum overlap required to obtain uniform distribution with 110° tips and 20" spacing.
Suggested Minimum Spray Height: 16"-18" above what is being sprayed (to plant, not ground).
Optimum Spray Height: 20"

- Excellent spray distribution over a wide range of pressures.
- Ideal for rigs equipped with sprayer controllers.
- Reduces drift at lower pressures, better coverage at higher pressures.

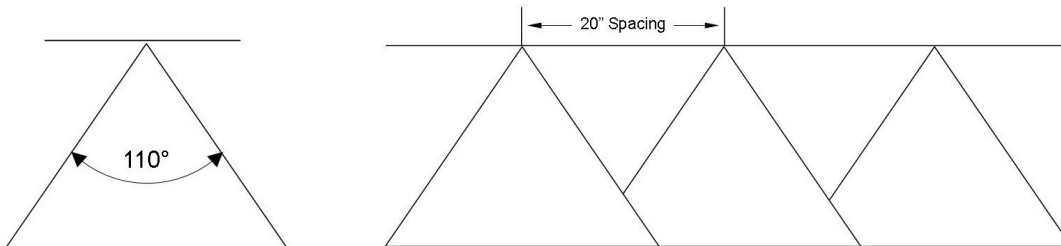

NOTES:

Warranty

LIMITED WARRANTY FOR NEW AG SPRAY EQUIPMENT

WHO MAY USE THIS LIMITED WARRANTY. This limited warranty (the "Limited Warranty") is provided by Ag Spray Equipment to the original purchaser ("you") of the Equipment (as defined below) from Ag Spray Equipment or one of Ag Spray Equipment's authorized dealers. This Limited Warranty does not apply to any subsequent owner or other transferee of the Equipment. THIS LIMITED WARRANTY GIVES YOU SPECIFIC LEGAL RIGHTS, AND YOU MAY ALSO HAVE OTHER RIGHTS WHICH VARY FROM STATE TO STATE.

WHAT THIS LIMITED WARRANTY COVERS AND FOR HOW LONG. Ag Spray Equipment warrants that any new Equipment will be free from defects in material and workmanship for a period of **one (1) year** (homeowner), **90 days** (commercial user), after delivery of the Equipment to you (the "Warranty Period"). The Warranty Period is not extended if Ag Spray Equipment repairs or replaces the Equipment.

WHAT IS NOT COVERED BY THIS LIMITED WARRANTY. This Limited Warranty does not apply to: (1) used Equipment; (2) any Equipment that has been altered, changed, repaired or treated since its delivery to you, other than by Ag Spray Equipment or its authorized dealers; (3) damage or depreciation due to normal wear and tear; (4) defects or damage due to failure to follow Ag Spray Equipment's operator's manual, specifications or other written instructions, or improper storage, operation, maintenance, application or installation of parts; (5) defects or damage due to misuse, accident or neglect, "acts of God" or other events beyond Ag Spray Equipment's reasonable control; (6) accessories, attachments, tools or parts that were not manufactured by Ag Spray Equipment, whether or not sold or operated with the Equipment; or (7) rubber parts, such as tires, hoses and grommets.

HOW TO OBTAIN WARRANTY SERVICE. To obtain warranty service under this Limited Warranty, you must (1) provide written notice to Ag Spray Equipment of the defect during the Warranty Period and within **thirty (30)** days after the defect becomes apparent or the repair becomes necessary, at the following address: Ag Spray Equipment, 1000 Fimco Lane, North Sioux City, SD 57049; and (2) make the Equipment available to Ag Spray Equipment or an authorized dealer within a reasonable period of time. For more information about this Limited Warranty, please call: **800-274-1025** or your local Ag Spray location.

WHAT REMEDIES ARE AVAILABLE UNDER THIS LIMITED WARRANTY. If the conditions set forth above are fulfilled and the Equipment or any part thereof is found to be defective, Ag Spray Equipment shall, at its own cost, and at its option, either repair or replace the defective Equipment or part. Ag Spray Equipment will pay for shipping and handling fees to return the repaired or replacement Equipment or part to you.

LIMITATION OF IMPLIED WARRANTIES AND OTHER REMEDIES. THE REMEDIES DESCRIBED ABOVE ARE YOUR SOLE AND EXCLUSIVE REMEDIES, AND AG SPRAY EQUIPMENT'S SOLE LIABILITY, FOR ANY BREACH OF THIS LIMITED WARRANTY. TO THE EXTENT APPLICABLE, ANY IMPLIED WARRANTIES, INCLUDING, WITHOUT LIMITATION, THE IMPLIED WARRANTIES OF MERCHANTABILITY AND FITNESS FOR A PARTICULAR PURPOSE, SHALL BE LIMITED IN DURATION TO THE WARRANTY PERIOD, AND THE REMEDIES AVAILABLE FOR BREACH THEREOF SHALL BE LIMITED TO THE REMEDIES AVAILABLE UNDER THIS EXPRESS LIMITED WARRANTY. SOME STATES DO NOT ALLOW LIMITATIONS ON HOW LONG AN IMPLIED WARRANTY LASTS, SO THE ABOVE LIMITATION MAY NOT APPLY TO YOU. IN NO EVENT SHALL AG SPRAY EQUIPMENT'S LIABILITY UNDER THIS LIMITED WARRANTY EXCEED THE ACTUAL AMOUNT PAID BY YOU FOR THE DEFECTIVE EQUIPMENT, NOR SHALL AG SPRAY EQUIPMENT BE LIABLE, UNDER ANY CIRCUMSTANCES, FOR ANY CONSEQUENTIAL, INCIDENTAL, SPECIAL OR PUNITIVE DAMAGES OR LOSSES, WHETHER DIRECT OR INDIRECT. SOME STATES DO NOT ALLOW THE EXCLUSION OR LIMITATION OF INCIDENTAL OR CONSEQUENTIAL DAMAGES, SO THE ABOVE LIMITATION OR EXCLUSION MAY NOT APPLY TO YOU.